

J - Bracket Sign Mounting Hardware

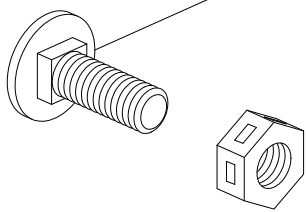
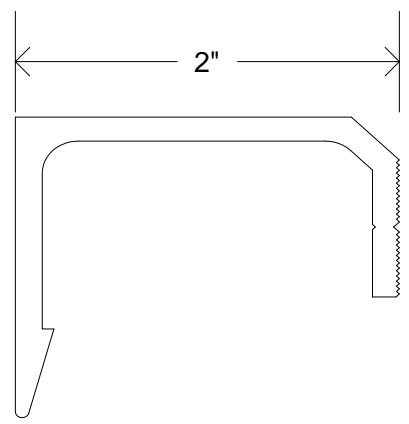
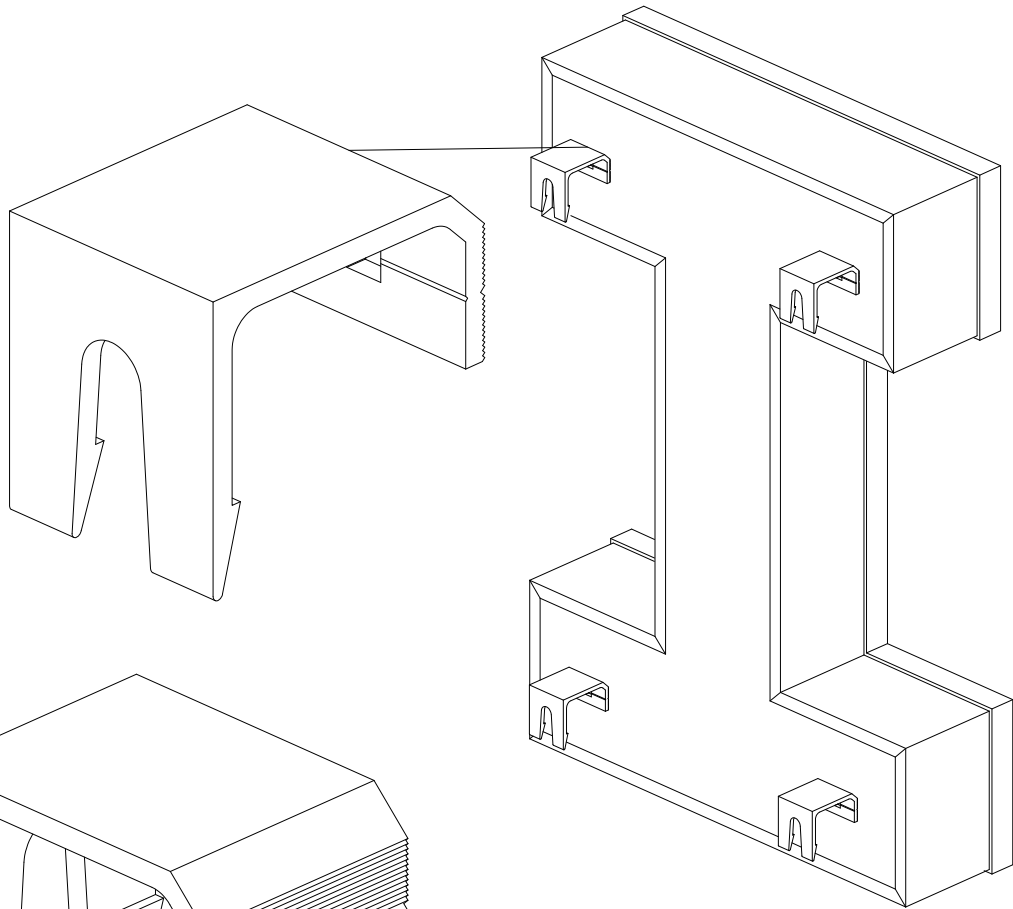

WORKS GREAT FOR:

- CHANNEL LETTERS
- REVERSE CHANNEL LETTERS
- SINGLE FACE CABINETS
- MDO PANELS
- AWNINGS

ADVANTAGES

- * Reduce field installation labor - No need to remove faces for mounting.
- * Engineered to withstand up to 50 Lbs. per bracket.
- * Sturdy aluminum construction (no rusting).
- * Accepts any off the shelf 1/4" carriage bolt & lock nut.

	MODEL #
1 1/2" J-BRACKET	JB-150

**Sign
Specialties
Incorporated**

120 15TH ST NE, WATERTOWN, SD 57201
PH #: (605) 886-4545 FAX #: (605) 886-5514

WWW.SIGNSPEC.NET

* Samples available upon request.